

CARACTERÍSTICAS

- Funcionamiento interferencia mecánica entre rosca y hormigón.
- Empleo para cargas altas. Alta resistencia al fuego.
- Homologado para 2 profundidades de instalación y hasta 3 para el Ø10.
- Uso para hormigón fisurado y no fisurado.
- Cumple con la guía VdS CEA 4001:2021-01(07) "Guidelines for sprinklers systems. Planning and installation"
- Adecuado cuando se tienen distancias entre anclajes o al borde reducidas.
- Empleo para cargas estáticas o cuasi-estáticas y cargas sísmicas C1&C2.
- Fácil instalación.
- Instalación directa a través del propio taladro de la placa de anclaje.
- Necesario taladro previo; la rosca en el material base se crea durante la instalación del anclaje.
- Reutilizable
- Puede ser desmontado, dejando la superficie diáfana.
- Variedad de longitudes y métricas, flexibilidad en el montaje
- VdS disponible desde Ø8 hasta Ø18
- Disponible en INDEXcal

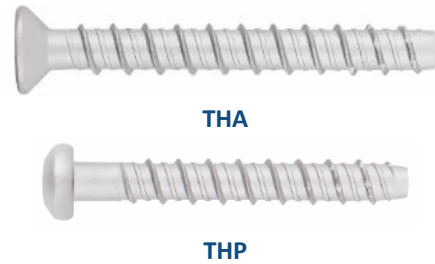

MATERIAL BASE



RANGO DE MEDIDAS

Ø5 - Ø18

CONDICIÓN DE TALADRO



SECO HUMEDO INUNDADO

CARGAS MÁXIMAS RECOMENDADAS A TRACCIÓN EN HORMIGÓN FISURADO Y NO FISURADO [kg]

APLICACIONES

- Fijaciones estructurales en hormigón fisurado y no fisurado en interior
- Acrisolamientos, ventanas y escaparates
- Estanterías y racks
- Instalación de barandillas y pasamanos en interiores
- Fijación de estructuras de madera a hormigón.

HOMOLOGACIONES





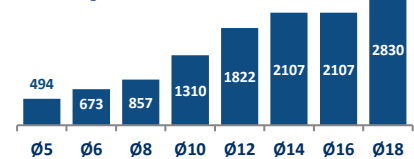





TH/TF



EJEMPLOS DE APLICACIÓN



1. GAMA						
ITEM	CÓDIGO	MED.	FOTO	DESCRIPCION	MATERIAL	RECUBRIMIENTO
1	THE	Ø5 - Ø18		Cabeza hexagonal con arandela estampada	Acero al carbono estampado, recubrimiento ATLANTIS	
2	THA	Ø5 - Ø10		Cabeza avellanada	Acero al carbono estampado, recubrimiento ATLANTIS	
3	THT	Ø6		Cabeza truss	Acero al carbono estampado, recubrimiento ATLANTIS	
4	THP	Ø5 - Ø8		Cabeza "pan"	Acero al carbono estampado, recubrimiento ATLANTIS	

2. DATOS INSTALACIÓN

2.1. PLANO DE INSTALACIÓN

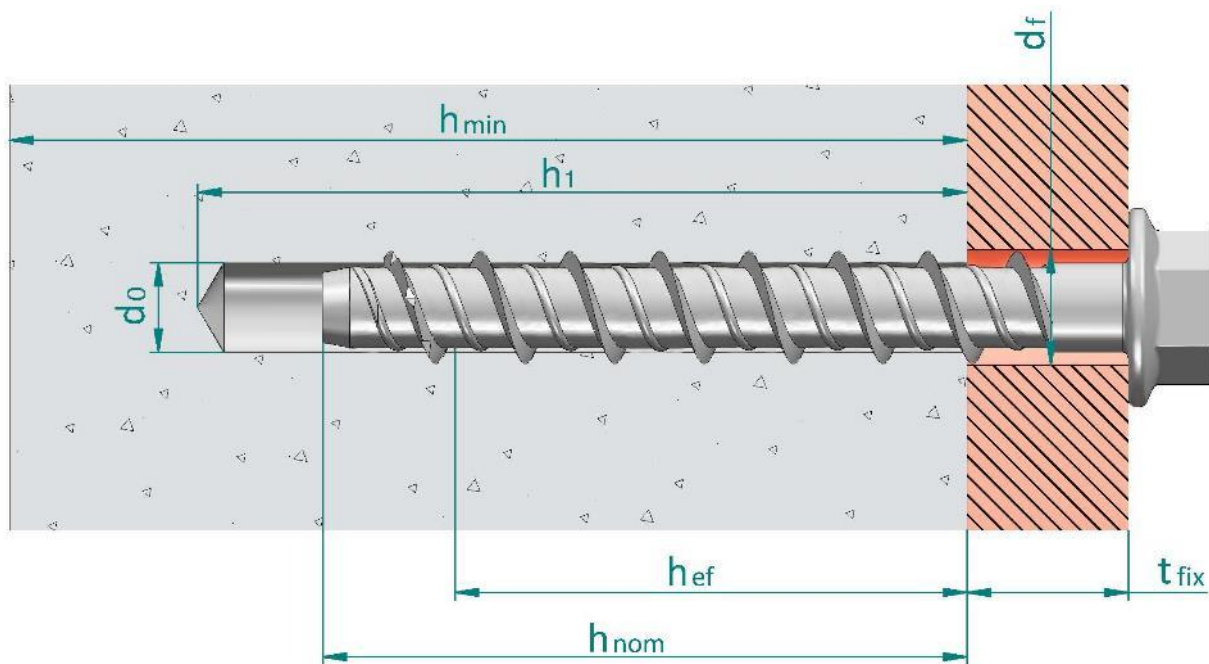

- d_0 : Diámetro nominal de broca
- d_b : Espesor del fondo de la losa
- d_f : Diámetro del taladro de paso en la placa de anclaje
- h_{ef} : Profundidad efectiva del anclaje
- h_1 : Profundidad del agujero
- h_{nom} : Profundidad de instalación en el hormigón
- h_{min} : Espesor mínimo del elemento de hormigón
- t_{fix} : Espesor de la placa de anclaje

Posición admisible del anclaje

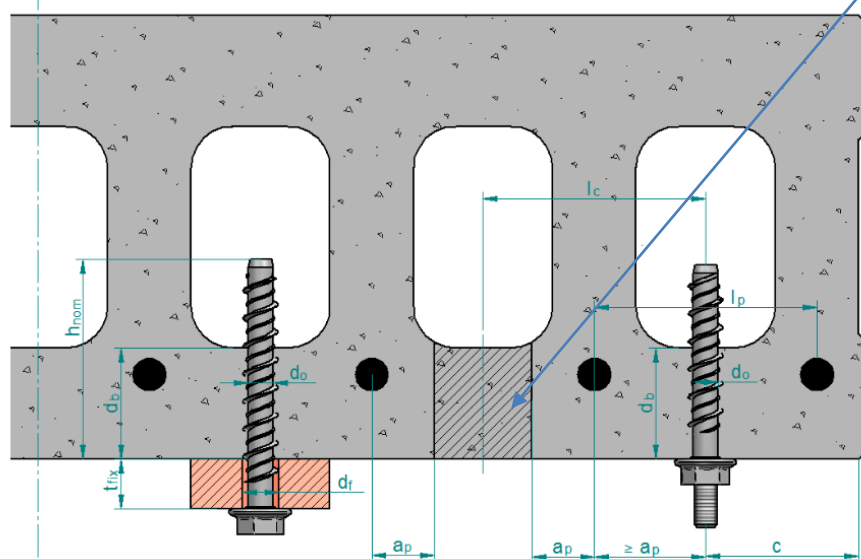

2.2. HOMOLOGACION PARA CARGAS SISMICAS

Familia	Código	Medida (Letra)	Homologado	C1	C2	Familia	Código	Medida	Homologado	C1	C2
[--]	[--]	[--]	ETA	[--]	[--]	[--]	[--]	[--]	ETA	[--]	[--]
THE	THE05040	Ø5 x 40 (A)	✓*	--	--	THE	THE16100	Ø16 x 100	✓	--	--
	THE05050	Ø5 x 50 (A)	✓*	--	--		THE16150	Ø16 x 150	✓	--	--
	THE05060	Ø5 x 60 (B)	✓*	--	--		THE18100	Ø18 x 100	✓	--	--
	THE05080	Ø5 x 80 (D)	✓*	--	--		THE18130	Ø18 x 130	✓	--	--
	THE05100	Ø5 x 100 (E)	✓*	--	--		THE18160	Ø18 x 160	✓	✓	✓
	THE06035	Ø6 x 35	✓	--	--		THE18180	Ø18 x 180	✓	✓	✓
	THE06040	Ø6 x 40	✓	--	--		THE18200	Ø18 x 200	✓	✓	✓
	THE06045	Ø6 x 45	✓	✓	--		THA05040	Ø5 x 40 (A)	✓*	--	--
	THE06050	Ø6 x 50	✓	✓	--		THA05060	Ø5 x 60 (B)	✓*	--	--
	THE06060	Ø6 x 60	✓	✓	--		THA05080	Ø5 x 80 (D)	✓*	--	--
	THE06070	Ø6 x 70	✓	✓	--	THA05100	Ø5 x 100 (E)	✓*	--	--	
	THE06080	Ø6 x 80	✓	✓	--	THA06045	Ø6 x 45	✓	--	--	
	THE06100	Ø6 x 100	✓	✓	--	THA06050	Ø6 x 50	✓	✓	--	
	THE06120	Ø6 x 120	✓	✓	--	THA06060	Ø6 x 60	✓	✓	--	
	THE08055	Ø8 x 55	✓	✓	✓	THA06080	Ø6 x 80	✓	✓	--	
	THE08060	Ø8 x 60	✓	✓	✓	THA06100	Ø6 x 100	✓	✓	--	
	THE08070	Ø8 x 70	✓	✓	✓	THA06120	Ø6 x 120	✓	✓	--	
	THE08075	Ø8 x 75	✓	✓	✓	THA06140	Ø6 x 140	✓	✓	--	
	THE08080	Ø8 x 80	✓	✓	✓	THA08060	Ø8 x 60	✓	✓	✓	
	THE08090	Ø8 x 90	✓	✓	✓	THA08080	Ø8 x 80	✓	✓	✓	
	THE08100	Ø8 x 100	✓	✓	✓	THA08100	Ø8 x 100	✓	✓	✓	
	THE08110	Ø8 x 110	✓	✓	✓	THA08120	Ø8 x 120	✓	✓	✓	
	THE08120	Ø8 x 120	✓	✓	✓	THA10100	Ø10 x 100	✓	✓	✓	
	THE08140	Ø8 x 140	✓	✓	✓	THA10120	Ø10 x 120	✓	✓	✓	
	THE10060	Ø10 x 60	✓	--	--	THT06040	Ø5 x 40 (A)	✓	--	--	
	THE10070	Ø10 x 70	✓	--	--	THT06050	Ø5 x 60 (B)	✓	✓	--	
	THE10080	Ø10 x 80	✓	--	--	THT06060	Ø5 x 80 (D)	✓	✓	--	
	THE10090	Ø10 x 90	✓	✓	✓	THP05040	Ø5 x 40 (A)	✓*	--	--	
	THE10100	Ø10 x 100	✓	✓	✓	THP05060	Ø5 x 60 (B)	✓*	--	--	
	THE10120	Ø10 x 120	✓	✓	✓	THP06040	Ø6 x 40	✓	--	--	
	THE10140	Ø10 x 140	✓	✓	✓	THP06050	Ø6 x 50	✓	✓	--	
	THE10160	Ø10 x 160	✓	✓	✓	THP06060	Ø6 x 60	✓	✓	--	
	THE10180	Ø10 x 180	✓	✓	✓	THP06080	Ø6 x 80	✓	✓	--	
	THE12080	Ø12 x 80	✓	--	--	THP06100	Ø6 x 100	✓	✓	--	
	THE12090	Ø12 x 90	✓	--	--	THP08060	Ø8 x 60	✓	✓	✓	
	THE12100	Ø12 x 100	✓	✓	✓	THP08080	Ø8 x 80	✓	✓	✓	
	THE12110	Ø12 x 110	✓	✓	✓						
	THE12130	Ø12 x 130	✓	✓	✓						
	THE12150	Ø12 x 150	✓	✓	✓						
	THE14080	Ø14 x 80	✓	--	--						
THE14100	Ø14 x 100	✓	--	--							
THE14110	Ø14 x 110	✓	✓	✓							
THE14120	Ø14 x 120	✓	✓	✓							
THE14130	Ø14 x 130	✓	✓	✓							
THE14140	Ø14 x 140	✓	✓	✓							
THE14160	Ø14 x 160	✓	✓	✓							

3.PARAMETROS DE INSTALACIÓN (HORMIGON)

Parámetros de instalación generales											Profundidad de instalación estándar ($h_{ef, std}$)								Profundidad de instalación reducida ($h_{ef, red}$)																					
Familia	Código	Medida (Letra)	Homologado	Diámetro de broca	Diámetro del agujero del espesor a fijar	Llave de instalación	Par de instalación máximo	Distancia mínima entre anclajes	Distancia mínima al borde	Esesor mínimo de hormigón	Profundidad del taladro	Profundidad instalación	Profundidad efectiva	Esesor a fijar	Distancia crítica entre ejes (cono)	Distancia crítica al borde (cono)	Distancia crítica entre ejes (fisuración)	Distancia crítica al borde (fisuración)	Esesor mínimo de hormigón	Profundidad del taladro	Profundidad instalación	Profundidad efectiva	Esesor a fijar	Distancia crítica entre ejes (cono)	Distancia crítica al borde (cono)	Distancia crítica entre ejes (fisuración)	Distancia crítica al borde (fisuración)													
[--]	[--]	[--]	ETA	d_0 [mm]	d_f [mm]	SW/Tx [--]	T_{inst} [Nm]	S_{min} [mm]	C_{min} [mm]	h_{min} [mm]	h_1 [mm]	h_{nom} [mm]	h_{ef} [mm]	t_{fix} [mm]	$S_{cr,N}$ [mm]	$C_{cr,N}$ [mm]	$S_{cr,sp}$ [mm]	$C_{cr,sp}$ [mm]	h_{min} [mm]	h_1 [mm]	h_{nom} [mm]	h_{ef} [mm]	t_{fix} [mm]	$S_{cr,N}$ [mm]	$C_{cr,N}$ [mm]	$S_{cr,sp}$ [mm]	$C_{cr,sp}$ [mm]													
THE	THE05040	Ø5 x 40(A)	✓*	5	6,5 - 8	SW 8	8	35	35	--	--	--	--	--	--	--	--	--	80	45	35	26,5	5	80	40	80	40													
	THE05050	Ø5 x 50(A)	✓*			SW 8				5																														
	THE05060	Ø5 x 60(B)	✓*			SW 8				15																														
	THE05080	Ø5 x 80(D)	✓*			SW 8				35																														
	THE05100	Ø5 x 100(E)	✓*			SW 8				55																														
	THE06035	Ø6 x 35	✓	6	7,5 - 9	SW 10	10	35	35	--	--	--	--	--	--	--	--	--	100	45	35	26,0	--	78	39	90	45													
	THE06040	Ø6 x 40	✓			SW 10				5																														
	THE06045	Ø6 x 45	✓			SW 10				10																														
	THE06050	Ø6 x 50	✓			SW 10				15																														
	THE06060	Ø6 x 60	✓			SW 10				25																														
	THE06070	Ø6 x 70	✓			SW 10				35																														
	THE06080	Ø6 x 80	✓			SW 10				45																														
	THE06100	Ø6 x 100	✓			SW 10				65																														
	THE06120	Ø6 x 120	✓			SW 10				85																														
	THE08055	Ø8 x 55	✓			8				10,5 - 12	SW 13	20	35	35	--	--	--	--					--					--	--	--	--	100	60	50	37,5	5	113	57	130	65
	THE08060	Ø8 x 60	✓								SW 13				10																									
	THE08070	Ø8 x 70	✓								SW 13				20																									
	THE08075	Ø8 x 75	✓	SW 13	25																																			
	THE08080	Ø8 x 80	✓	SW 13	30																																			
	THE08090	Ø8 x 90	✓	SW 13	40																																			
	THE08100	Ø8 x 100	✓	SW 13	50																																			
	THE08110	Ø8 x 110	✓	SW 13	60																																			
	THE08120	Ø8 x 120	✓	SW 13	70																																			
	THE08140	Ø8 x 140	✓	SW 13	90																																			

*Ø5 Homologado solamente para uso en hormigón y en losas alveolares prefabricadas para sistemas no-estructurales redundantes

Parámetros de instalación generales										Profundidad de instalación estándar (h _{ef, std})								Profundidad de instalación reducida (h _{ef, red})										
Familia	Código	Medida (Letra)	Homologado	Diámetro de broca	Diámetro del agujero del espesor a fijar	Llave de instalación	Par de instalación máximo	Distancia mínima entre anclajes	Distancia mínima al borde	Esesor mínimo de hormigón	Profundidad del taladro	Profundidad instalación	Profundidad efectiva	Esesor a fijar	Distancia crítica entre ejes (cono)	Distancia crítica al borde (cono)	Distancia crítica entre ejes (fisuración)	Distancia crítica al borde (fisuración)	Esesor mínimo de hormigón	Profundidad del taladro	Profundidad instalación	Profundidad efectiva	Esesor a fijar	Distancia crítica entre ejes (cono)	Distancia crítica al borde (cono)	Distancia crítica entre ejes (fisuración)	Distancia crítica al borde (fisuración)	
[--]	[--]	[--]	ETA	d ₀	d _f	SW/Tx	T _{inst}	S _{min}	C _{min}	h _{min}	h ₁	h _{nom}	h _{ef}	t _{fix}	S _{cr,N}	C _{cr,N}	S _{cr,sp}	C _{cr,sp}	h _{min}	h ₁	h _{nom}	h _{ef}	t _{fix}	S _{cr,N}	C _{cr,N}	S _{cr,sp}	C _{cr,sp}	
				[mm]	[mm]	[--]	[Nm]	[mm]	[mm]	[mm]	[mm]	[mm]	[mm]	[mm]	[mm]	[mm]	[mm]	[mm]	[mm]	[mm]	[mm]	[mm]	[mm]	[mm]	[mm]	[mm]	[mm]	[mm]
THE	THE10060	Ø10 x 60	✓	10	12,5 - 14	SW 15	30	50	40	--	--	--	--	--	--	--	--	--	100	65	55	41,5	5	125	63	140	70	
	THE10070	Ø10 x 70	✓			15																						
	THE10080	Ø10 x 80	✓			25																						
	THE10090	Ø10 x 90	✓			35																						
	THE10100	Ø10 x 100	✓			5																						
	THE10120	Ø10 x 120	✓			15																						
	THE10140	Ø10 x 140	✓			35																						
	THE10160	Ø10 x 160	✓			55																						
	THE10180	Ø10 x 180	✓			75																						
	THE12080	Ø12 x 80	✓	12	14,8 - 16	SW 18	50	75	45	--	--	--	--	--	--	--	--	--	120	90	75	58,0	5	174	87	190	95	
	THE12090	Ø12 x 90	✓			15																						
	THE12100	Ø12 x 100	✓			25																						
	THE12110	Ø12 x 110	✓			35																						
	THE12130	Ø12 x 130	✓			5																						
	THE12150	Ø12 x 150	✓			170																						
	THE14080	Ø14 x 80	✓	14	16,9 - 18	SW 21	70	80	50	--	--	--	--	--	--	--	--	--	120	90	75	58,0	5	174	87	190	95	
	THE14100	Ø14 x 100	✓			15																						
	THE14110	Ø14 x 110	✓			25																						
	THE14120	Ø14 x 120	✓			35																						
	THE14130	Ø14 x 130	✓			5																						
THE14140	Ø14 x 140	✓	185																									
THE16100	Ø16 x 100	✓	16	18,9 - 20	SW24	80	80	50	--	--	--	--	--	--	--	--	--	115	100	80	58	20	174	87	180	90		
THE16150	Ø16 x 150	✓			70																							
THE18100	Ø18 x 100	✓	18	20,9 - 22	SW 24	90	90	55	--	--	--	--	--	--	--	--	--	--	140	110	90	69,5	10	209	105	230	115	
THE18130	Ø18 x 130	✓			40																							
THE18160	Ø18 x 160	✓			70																							
THE18180	Ø18 x 180	✓			90																							
THE18200	Ø18 x 200	✓			20																							
					225																							

Parámetros de instalación generales										Profundidad de instalación estándar (h _{ef, std})								Profundidad de instalación reducida (h _{ef, red})									
Familia	Código	Medida (Letra)	Homologado	Diámetro de broca	Diámetro del agujero del espesor a fijar	Llave de instalación	Par de instalación máximo	Distancia mínima entre anclajes	Distancia mínima al borde	Esesor mínimo de hormigón	Profundidad del taladro	Profundidad instalación	Profundidad efectiva	Esesor a fijar	Distancia crítica entre ejes (cono)	Distancia crítica al borde (cono)	Distancia crítica entre ejes (fisuración)	Distancia crítica al borde (fisuración)	Esesor mínimo de hormigón	Profundidad del taladro	Profundidad instalación	Profundidad efectiva	Esesor a fijar	Distancia crítica entre ejes (cono)	Distancia crítica al borde (cono)	Distancia crítica entre ejes (fisuración)	Distancia crítica al borde (fisuración)
[--]	[--]	[--]	ETA	d ₀ [mm]	d _f [mm]	SW/Tx [--]	T _{inst} [Nm]	S _{min} [mm]	C _{min} [mm]	h _{min} [mm]	h ₁ [mm]	h _{nom} [mm]	h _{ef} [mm]	t _{fix} [mm]	S _{cr,N} [mm]	C _{cr,N} [mm]	S _{cr,sp} [mm]	C _{cr,sp} [mm]	h _{min} [mm]	h ₁ [mm]	h _{nom} [mm]	h _{ef} [mm]	t _{fix} [mm]	S _{cr,N} [mm]	C _{cr,N} [mm]	S _{cr,sp} [mm]	C _{cr,sp} [mm]
THA	THA05040	Ø5 x 40(A)	✓*	5	6,5 - 8	TX25	8	35	35	80	55	45	35,0	15	105	53	105	53	80	45	35	26,5	5	80	40	80	40
	THA05060	Ø5 x 60(B)	✓*			25																					
	THA05080	Ø5 x 80(D)	✓*			45																					
	THA05100	Ø5 x 100(E)	✓*			65																					
	THA06045	Ø6 x 45	✓	6	7,5 - 9	TX30	10	35	35	100	65	55	43,0	5	129	65	170	85	100	45	35	26,0	10	78	39	90	45
	THA06050	Ø6 x 50	✓			15																					
	THA06060	Ø6 x 60	✓			25																					
	THA06080	Ø6 x 80	✓			45																					
	THA06100	Ø6 x 100	✓			65																					
	THA06120	Ø6 x 120	✓			85																					
	THA06140	Ø6 x 140	✓	105																							
	THA08060	Ø8 x 60	✓	8	10,5 - 12	TX45	20	35	35	100	75	65	50,5	15	152	76	200	100	100	60	50	37,5	10	113	57	130	65
	THA08080	Ø8 x 80	✓			30																					
	THA08100	Ø8 x 100	✓			50																					
THA08120	Ø8 x 120	✓	70																								
THA10100	Ø10 x 100	✓	10	12,5 - 14	TX50	30	50	40	135	95	85	67,0	15	201	101	210	105	100	65	55	41,5	45	125	63	140	70	
THA10120	Ø10 x 120	✓			65																						
THT	THT06040	Ø6 x 40	✓	6	7,5 - 9	TX30	10	35	35	100	65	55	43,0	5	129	65	170	85	100	45	35	26,0	5	78	39	90	45
	THT06050	Ø6 x 50	✓			15																					
	THT06060	Ø6 x 60	✓			25																					
THP	THP05040	Ø5 x 40(A)	✓*	5	6,5 - 8	TX30	8	35	35	80	55	45	35,0	15	105	53	105	53	80	45	35	26,5	5	80	40	80	40
	THP05060	Ø5 x 60(B)	✓*			25																					
	THP06040	Ø6 x 40	✓	6	7,5 - 9	TX40	10	35	35	100	65	55	43,0	5	129	65	170	85	100	45	35	26,0	5	78	39	90	45
	THP06050	Ø6 x 50	✓			15																					
	THP06060	Ø6 x 60	✓			25																					
	THP06080	Ø6 x 80	✓			45																					
	THP06100	Ø6 x 100	✓	65																							
	THP08060	Ø8 x 60	✓	8	10,5 - 12	TX45	20	35	35	100	75	65	50,5	15	152	76	200	100	100	60	50	37,5	10	113	57	130	65
THP08080	Ø8 x 80	✓	30																								

*Ø5 Homologado solamente para uso en hormigón y en losas alveolares prefabricadas para sistemas no-estructurales redundantes

4.PARAMETROS DE INSTALACIÓN (LOSAS ALVEOLARES) [Profundidad de instalación reducida/intermedia/estándar]

Parámetros de instalación generales											Profundidad de instalación ($h_{ef1}/ h_{ef2}/ h_{ef3}$)							
Familia	Código	Medida (Letra)	Homologado	Diámetro de broca	Diámetro del agujero del espesor a fijar	Llave de instalación	Par de instalación máximo	Distancia mínima entre anclajes	Distancia mínima al borde	Espesor del fondo de la losa	Profundidad del taladro	Profundidad instalación	Profundidad efectiva	Espesor a fijar	Distancia crítica entre ejes (cono)	Distancia crítica al borde(cono)	Distancia crítica entre ejes (fisuración)	Distancia crítica al borde(fisuración)
[--]	[--]	[--]	ETA	d_0 [mm]	d_f [mm]	SW/Tx [--]	T_{inst} [Nm]	S_{min} [mm]	C_{min} [mm]	d_b [mm]	h_1 [mm]	h_{nom} [mm]	h_{ef} [mm]	t_{fix} [mm]	$S_{cr,N}$ [mm]	$C_{cr,N}$ [mm]	$S_{cr,sp}$ [mm]	$C_{cr,sp}$ [mm]
THE	THE05040	Ø5 x 40(A)	✓*	5	6,5 - 8	SW 8	8	35	35	25/30/40	30/40/45	30/40/45	20/22/26,5	10/--/--	60/66/80	30/33/40	80	80
	THE05050	Ø5 x 50(A)	✓*			SW 8								20/10/5				
	THE05060	Ø5 x 60(B)	✓*			SW 8								30/20/15				
	THE05080	Ø5 x 80(D)	✓*			SW 8								50/40/35				
	THE05100	Ø5 x 100(E)	✓*			SW 8								70/60/55				
	THE06035	Ø6 x 35	✓	6	7,5 - 9	SW 10	10	35	35	25/30/40	30/40/45	30/40/45	20/22/26	5/--/--	60/66/78	30/33/39	90	45
	THE06040	Ø6 x 40	✓			SW 10								10/--/--				
	THE06045	Ø6 x 45	✓			SW 10								15/5/--				
	THE06050	Ø6 x 50	✓			SW 10								20/10/5				
	THE06060	Ø6 x 60	✓			SW 10								30/20/15				
	THE06070	Ø6 x 70	✓			SW 10								40/30/25				
	THE06080	Ø6 x 80	✓			SW 10								50/40/35				
	THE06100	Ø6 x 100	✓			SW 10								70/60/55				
	THE06120	Ø6 x 120	✓			SW 10								90/80/75				
THE06140	Ø6 x 140	✓	SW 10			110/100/95												
THA	THA05040	Ø5 x 40(A)	✓*	5	6,5 - 8	TX25	8	35	35	25/30/40	30/40/45	30/40/45	20/22/26,5	10/--/--	60/66/80	30/33/40	80	80
	THA05060	Ø5 x 60(B)	✓*			TX25								30/20/15				
	THA05080	Ø5 x 80(D)	✓*			TX25								50/40/35				
	THA05100	Ø5 x 100(E)	✓*			TX25								70/60/55				
	THA06045	Ø6 x 45	✓	6	7,5 - 9	TX30	10	35	35	25/30/40	30/40/45	30/40/45	20/22/26	15/5/--	60/66/78	30/33/39	90	45
	THA06050	Ø6 x 50	✓			TX30								20/10/5				
	THA06060	Ø6 x 60	✓			TX30								30/20/15				
	THA06080	Ø6 x 80	✓			TX30								50/40/35				
	THA06100	Ø6 x 100	✓			TX30								70/60/55				
	THA06120	Ø6 x 120	✓			TX30								90/80/75				
	THA06140	Ø6 x 140	✓			TX30								110/100/95				

*Ø5 Homologado solamente para uso en hormigón y en losas alveolares prefabricadas para sistemas no-estructurales redundantes

Parámetros de instalación generales										Profundidad de instalación ($h_{ef1}/ h_{ef2}/ h_{ef3}$)								
Familia	Código	Medida (Letra)	Homologado	Diámetro de broca	Diámetro del agujero del espesor a fijar	Llave de instalación	Par de instalación máximo	Distancia mínima entre anclajes	Distancia mínima al borde	Esesor del fondo de la losa	Profundidad del taladro	Profundidad instalación	Profundidad efectiva	Esesor a fijar	Distancia crítica entre ejes (cono)	Distancia crítica al borde (cono)	Distancia crítica entre ejes (fisuración)	Distancia crítica al borde (fisuración)
[--]	[--]	[--]	ETA	d_0	d_f	SW/Tx	T_{inst}	S_{min}	C_{min}	d_b	h_1	h_{nom}	h_{ef}	t_{fix}	$S_{cr,N}$	$C_{cr,N}$	$S_{cr,sp}$	$C_{cr,sp}$
				[mm]	[mm]	[--]	[Nm]	[mm]	[mm]	[mm]	[mm]	[mm]	[mm]	[mm]	[mm]	[mm]	[mm]	[mm]
THT	THT06040	Ø6 x 40	✓	6	7,5 - 9	TX30	10	35	35	25/30/40	30/40/45	30/40/45	20/22/26	10/--/--	60/66/78	30/33/39	90	45
	THT06050	Ø6 x 50	✓			TX30								20/10/5				
	THT06060	Ø6 x 60	✓			TX30								30/20/15				
THP	THP05040	Ø5 x 40(A)	✓*	5	6,5 - 8	TX30	8	35	35	25/30/40	30/40/45	30/40/45	20/22/26,5	10/--/--	60/66/80	30/33/40	80	80
	THP05060	Ø5 x 60(B)	✓*			TX30								30/20/15				
	THP06040	Ø6 x 40	✓	6	7,5 - 9	TX40	10	35	35	25/30/40	30/40/45	30/40/45	20/22/26	10/--/--	60/66/78	30/33/39	90	45
	THP06050	Ø6 x 50	✓			TX40								20/10/5				
	THP06060	Ø6 x 60	✓			TX40								30/20/15				
	THP06080	Ø6 x 80	✓			TX40								50/40/35				
	THP06100	Ø6 x 100	✓			TX40								70/60/55				

*Ø5 Homologado solamente para uso en hormigón y en losas alveolares prefabricadas para sistemas no-estructurales redundantes

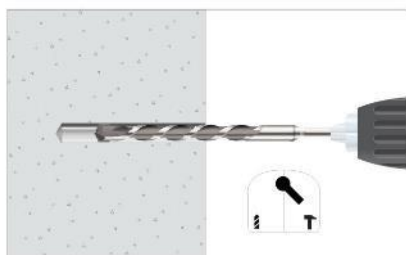
5. PROCESO DE INSTALACIÓN**5.1 INSTALACIÓN EN HORMIGÓN Y LOSAS ALVEOLARES****1. TALADRAR**

Comprobar que el hormigón esté bien compactado y sin poros significativos.

Admisible en taladros secos, húmedos o inundados.

Taladro en posición percusión o martillo.

Taladrar a diámetro y profundidad especificados.

**2. SOPLAR Y LIMPIAR**

Limpiar el agujero de restos de polvo y fragmentos del taladrado según indicaciones del gráfico.

Utilizar bomba de aire y cepillo.

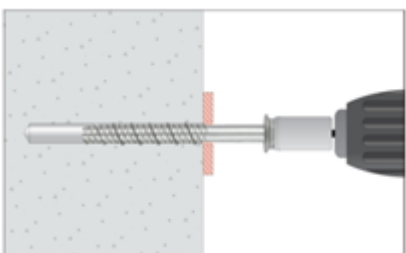
**3. INSTALAR**

Utilizar una llave de impacto que no exceda el torque máximo especificado en las tablas anteriores.

Utilizar el vaso o punta adecuado para cada medida.

La instalación debe hacerse a través del material a fijar.

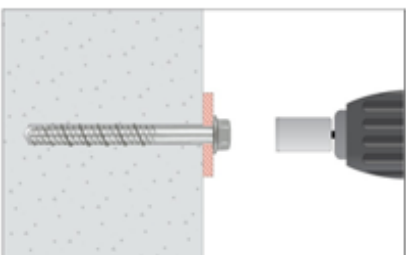
**4. APLICAR EL PAR DE APRIETE**

Insertar el anclaje en el agujero hasta que la cabeza quede enrasada con la superficie del material a fijar.

El anclaje tiene que ser ajustado después de la instalación.

6. RESISTENCIAS (HORMIGÓN)

Resistencias en hormigón C20/25 para un anclaje aislado sin efectos de distancia al borde ni de distancias entre anclajes es la indicada en la siguiente tabla:

Los valores subrayados y en cursiva indican fallo del acero, los valores en **negrita** indican fallo por hormigón y el resto indica fallo por extracción.
1 KN ≈ 100 kg

6.1 RESISTENCIAS CARACTERÍSTICAS (APLICACIONES ESTRUCTURALES) [kN]

Parámetros generales				Hormigón no fisurado				Hormigón fisurado											
Familia	Código	Medida	Homologado ETA	Tracción $N_{Rk, ucr}$		Cortadura $V_{Rk, ucr}$		Tracción $N_{Rk, cr}$		Cortadura $V_{Rk, cr}$									
				($h_{ef, std}$)	($h_{ef, red}$)	($h_{ef, std}$)	($h_{ef, red}$)	($h_{ef, std}$)	($h_{ef, red}$)	($h_{ef, std}$)	($h_{ef, red}$)								
THE	THE05040	Ø5 x 40	✓*	--	6,71	--	6,71	--	4,70	--	4,70								
	THE05050	Ø5 x 50	✓*	10,19	6,71	<u>8,19</u>	6,71	7,13	4,70	7,13	4,70								
	THE05060	Ø5 x 60	✓*																
	THE05080	Ø5 x 80	✓*																
	THE05100	Ø5 x 100	✓*																
	THE06035	Ø6 x 35	✓	--	5,00	--	<u>12,53</u>	--	4,57	--	9,36								
	THE06040	Ø6 x 40	✓																
	THE06045	Ø6 x 45	✓																
	THE06050	Ø6 x 50	✓																
	THE06060	Ø6 x 60	✓	13,87	5,00	<u>12,53</u>	<u>12,53</u>	9,71	4,57	11,17	9,36								
	THE06070	Ø6 x 70	✓																
	THE06080	Ø6 x 80	✓																
	THE06100	Ø6 x 100	✓																
	THE06120	Ø6 x 120	✓																
	THE08055	Ø8 x 55	✓									--	11,30	--	<u>19,57</u>	--	7,91	--	14,23
	THE08060	Ø8 x 60	✓																
	THE08070	Ø8 x 70	✓																
	THE08075	Ø8 x 75	✓																
	THE08080	Ø8 x 80	✓	17,65	11,30	<u>19,57</u>	<u>19,57</u>	12,36	7,91	15,69	14,23								
	THE08090	Ø8 x 90	✓																
	THE08100	Ø8 x 100	✓																
	THE08110	Ø8 x 110	✓																
	THE08120	Ø8 x 120	✓																
	THE08140	Ø8 x 140	✓																
	THE10060	Ø10 x 60	✓									--	13,15	--	25,65	--	9,21	--	17,95
	THE10070	Ø10 x 70	✓																
	THE10080	Ø10 x 80	✓																
	THE10090	Ø10 x 90	✓																
	THE10100	Ø10 x 100	✓	26,98	13,15	<u>27,40</u>	25,65	18,89	9,21	<u>27,40</u>	17,95								
	THE10120	Ø10 x 120	✓																
	THE10140	Ø10 x 140	✓																
	THE10160	Ø10 x 160	✓																
	THE10180	Ø10 x 180	✓																
	THE12080	Ø12 x 80	✓									--	21,73	--	<u>37,24</u>	--	15,21	--	35,44
	THE12090	Ø12 x 90	✓																
	THE12100	Ø12 x 100	✓																
	THE12110	Ø12 x 110	✓																
	THE12130	Ø12 x 130	✓	37,54	21,73	<u>37,24</u>	<u>37,24</u>	26,27	15,21	<u>37,24</u>	35,44								
	THE12150	Ø12 x 150	✓																
	THE14080	Ø14 x 80	✓	--	21,73	--	<u>52,72</u>	--	15,21	--	38,79								
THE14100	Ø14 x 100	✓																	
THE14110	Ø14 x 110	✓																	
THE14120	Ø14 x 120	✓																	
THE14130	Ø14 x 130	✓	43,41	21,73	<u>52,72</u>	<u>52,72</u>	30,39	15,21	<u>52,72</u>	38,79									
THE14140	Ø14 x 140	✓																	
THE14160	Ø14 x 160	✓																	
TFE16100	Ø16 x 100	✓									--	--	--	--	30,39	15,21	<u>52,72</u>	32,55	
TFE16150	Ø16 x 150	✓	43,41	21,73	<u>57,97</u>	46,50													
THE18100	Ø18 x 100	✓	--	28,50	--	75,82	--	19,95	--	53,07									
THE18130	Ø18 x 130	✓																	
THE18160	Ø18 x 160	✓																	
THE18180	Ø18 x 180	✓	58,31								28,50	<u>80,78</u>	75,82	40,82	19,95	<u>80,78</u>	53,07		
THE18200	Ø18 x 200	✓																	

*Ø5 Homologado solamente para uso en hormigón y en losas alveolares prefabricadas para sistemas no-estructurales redundantes

Parámetros generales				Hormigón no fisurado				Hormigón fisurado			
Familia	Código	Medida	Homologado ETA	Tracción $N_{RK, ucr}$		Cortadura $V_{RK, ucr}$		Tracción $N_{RK, cr}$		Cortadura $V_{RK, cr}$	
				($h_{ef, std}$)	($h_{ef, red}$)	($h_{ef, std}$)	($h_{ef, red}$)	($h_{ef, std}$)	($h_{ef, red}$)	($h_{ef, std}$)	($h_{ef, red}$)
THA	THA05040	Ø5 x 40	✓*	--	6,71	--	6,71	--	4,70	--	4,70
	THA05060	Ø5 x 60	✓*	10,19	6,71	<u>8,19</u>	6,71	7,13	4,70	7,13	4,70
	THA05080	Ø5 x 80	✓*								
	THA05100	Ø5 x 100	✓*								
	THA06045	Ø6 x 45	✓	--	5,00	--	<u>12,53</u>	--	4,57	--	9,36
	THA06050	Ø6 x 50	✓	--		--		--			
	THA06060	Ø6 x 60	✓	13,87	5,00	<u>12,53</u>	<u>12,53</u>	9,71	4,57	11,17	9,36
	THA06080	Ø6 x 80	✓								
	THA06100	Ø6 x 100	✓								
	THA06120	Ø6 x 120	✓								
	THA06140	Ø6 x 140	✓	17,65	11,30	<u>19,57</u>	<u>19,57</u>	12,36	7,91	15,69	14,23
	THA08060	Ø8 x 60	✓								
	THA08080	Ø8 x 80	✓								
	THA08100	Ø8 x 100	✓								
THA08120	Ø8 x 120	✓	26,98	13,15	<u>27,40</u>	25,65	18,89	9,21	<u>27,40</u>	17,95	
THA10100	Ø10 x 100	✓									
THA10120	Ø10 x 120	✓									
THT	THT06040	Ø6 x 40	✓	--	5,00	--	<u>12,53</u>	--	4,57	--	9,36
	THT06050	Ø6 x 50	✓	--		--		--			
	THT06060	Ø6 x 60	✓	13,87	5,00	<u>12,53</u>	<u>12,53</u>	9,71	4,57	11,17	9,36
THP	THP05040	Ø5 x 40	✓*	--	6,71	--	6,71	--	4,70	--	4,70
	THP05060	Ø5 x 60	✓*	10,19	6,71	<u>8,19</u>	6,71	7,13	4,70	7,13	4,70
	THP06040	Ø6 x 40	✓								
	THP06050	Ø6 x 50	✓								
	THP06060	Ø6 x 60	✓	13,87	5,00	<u>12,53</u>	<u>12,53</u>	9,71	4,57	11,17	9,36
	THP06080	Ø6 x 80	✓								
	THP06100	Ø6 x 100	✓								
	THP08060	Ø8 x 60	✓								
THP08080	Ø8 x 80	✓	17,65	11,30	<u>19,57</u>	<u>19,57</u>	12,36	7,91	15,69	14,23	

*Ø5 Homologado solamente para uso en hormigón y en losas alveolares prefabricadas para sistemas no-estructurales redundantes

6.2 RESISTENCIAS DE CALCULO (APLICACIONES ESTRUCTURALES) [kN]

Parámetros generales				Hormigón no fisurado				Hormigón fisurado			
Familia	Código	Medida	Homologado ETA	Tracción $N_{Rd, ucr}$		Cortadura $V_{Rd, ucr}$		Tracción $N_{Rd, cr}$		Cortadura $V_{Rd, cr}$	
				($h_{ef, std}$)	($h_{ef, red}$)	($h_{ef, std}$)	($h_{ef, red}$)	($h_{ef, std}$)	($h_{ef, red}$)	($h_{ef, std}$)	($h_{ef, red}$)
THE	THE05040	Ø5 x 40	✓*	--	4,47	--	4,47	--	3,13	--	3,13
	THE05050	Ø5 x 50	✓*	6,79	4,47	<u>5,46</u>	4,47	4,75	3,13	4,75	3,13
	THE05060	Ø5 x 60	✓*								
	THE05080	Ø5 x 80	✓*								
	THE05100	Ø5 x 100	✓*								
	THE06035	Ø6 x 35	✓	--	--	--	--	--	--	--	--
	THE06040	Ø6 x 40	✓	--	2,78	--	<u>8,35</u>	--	2,54	--	6,24
	THE06045	Ø6 x 45	✓	--		--		--			
	THE06050	Ø6 x 50	✓	--		--		--			
	THE06060	Ø6 x 60	✓	9,25	2,78	<u>8,35</u>	<u>8,35</u>	6,47	2,54	7,44	6,24
	THE06070	Ø6 x 70	✓								
	THE06080	Ø6 x 80	✓								
	THE06100	Ø6 x 100	✓								
	THE06120	Ø6 x 120	✓	--	6,28	--	<u>13,05</u>	--	4,39	--	9,49
	THE08055	Ø8 x 55	✓	--		--		--			
	THE08060	Ø8 x 60	✓	--		--		--			
	THE08070	Ø8 x 70	✓	11,77	6,28	<u>13,05</u>	<u>13,05</u>	8,24	4,39	10,46	9,49
	THE08075	Ø8 x 75	✓								
	THE08080	Ø8 x 80	✓								
	THE08090	Ø8 x 90	✓								
	THE08100	Ø8 x 100	✓								
	THE08110	Ø8 x 110	✓								
	THE08120	Ø8 x 120	✓								
	THE08140	Ø8 x 140	✓								
	THE10060	Ø10 x 60	✓	--	8,77	--	17,10	--	6,14	--	11,97
	THE10070	Ø10 x 70	✓	--		--		--			
	THE10080	Ø10 x 80	✓	--		--		--			
	THE10090	Ø10 x 90	✓	17,99	8,77	<u>18,27</u>	17,10	12,59	6,14	<u>18,27</u>	11,97
	THE10100	Ø10 x 100	✓								
	THE10120	Ø10 x 120	✓								
	THE10140	Ø10 x 140	✓								
	THE10160	Ø10 x 160	✓								
THE10180	Ø10 x 180	✓									
THE12080	Ø12 x 80	✓	--	14,49	--	<u>24,83</u>	--	10,14	--	23,63	
THE12090	Ø12 x 90	✓	--		--		--				
THE12100	Ø12 x 100	✓	--		--		--				
THE12110	Ø12 x 110	✓	25,02	14,49	<u>24,83</u>	<u>24,83</u>	17,52	10,14	<u>24,83</u>	23,63	
THE12130	Ø12 x 130	✓									
THE12150	Ø12 x 150	✓									
THE14080	Ø14 x 80	✓	--	21,73	--	<u>52,72</u>	--	15,21	--	38,79	
THE14100	Ø14 x 100	✓	--		--		--				
THE14110	Ø14 x 110	✓	--		--		--				
THE14120	Ø14 x 120	✓	43,41	21,73	<u>52,72</u>	<u>52,72</u>	30,39	15,21	<u>52,72</u>	38,79	
THE14130	Ø14 x 130	✓									
THE14140	Ø14 x 140	✓									
THE14160	Ø14 x 160	✓									
TFE16100	Ø16 x 100	✓	--	--	--	--	20,26	10,14	<u>38,65</u>	21,70	
TFE16150	Ø16 x 150	✓	28,94	14,49	<u>38,65</u>	31,00					
THE18100	Ø18 x 100	✓	--	19,00	--	50,54	--	13,30	--	35,38	
THE18130	Ø18 x 130	✓	--		--		--				
THE18160	Ø18 x 160	✓	38,87	19,00	<u>53,85</u>	50,54	27,21	13,30	<u>53,85</u>	35,38	
THE18180	Ø18 x 180	✓									
THE18200	Ø18 x 200	✓									

*Ø5 Homologado solamente para uso en hormigón y en losas alveolares prefabricadas para sistemas no-estructurales redundantes

Parámetros generales				Hormigón no fisurado				Hormigón fisurado			
Familia	Código	Medida	Homologado ETA	Tracción $N_{Rk, ucr}$		Cortadura $V_{Rk, ucr}$		Tracción $N_{Rk, cr}$		Cortadura $V_{Rk, cr}$	
				($h_{ef, std}$)	($h_{ef, red}$)	($h_{ef, std}$)	($h_{ef, red}$)	($h_{ef, std}$)	($h_{ef, red}$)	($h_{ef, std}$)	($h_{ef, red}$)
THA	THA05040	Ø5 x 40	✓*	--	4,47	--	4,47	--	3,13	--	3,13
	THA05060	Ø5 x 60	✓*	6,79	4,47	<u>5,46</u>	4,47	4,75	3,13	4,75	3,13
	THA05080	Ø5 x 80	✓*								
	THA05100	Ø5 x 100	✓*								
	THA06045	Ø6 x 45	✓	--	2,78	--	<u>8,35</u>	--	2,54	--	6,24
	THA06050	Ø6 x 50	✓								
	THA06060	Ø6 x 60	✓	9,25	2,78	<u>8,35</u>	<u>8,35</u>	6,47	2,54	7,44	6,24
	THA06080	Ø6 x 80	✓								
	THA06100	Ø6 x 100	✓								
	THA06120	Ø6 x 120	✓								
	THA06140	Ø6 x 140	✓								
	THA08060	Ø8 x 60	✓	--	6,28	--	<u>13,05</u>	--	4,39	--	9,49
	THA08080	Ø8 x 80	✓	11,77	6,28	<u>13,05</u>	<u>13,05</u>	8,24	4,39	10,46	9,49
	THA08100	Ø8 x 100	✓								
THA08120	Ø8 x 120	✓									
THA10100	Ø10 x 100	✓	17,99	8,77	<u>18,27</u>	17,10	12,59	6,14	<u>18,27</u>	11,97	
THA10120	Ø10 x 120	✓									
THT	THT06040	Ø6 x 40	✓	--	2,78	--	<u>8,35</u>	--	2,54	--	6,24
	THT06050	Ø6 x 50	✓								
	THT06060	Ø6 x 60	✓	9,25	2,78	<u>8,35</u>	<u>8,35</u>	6,47	2,54	7,44	6,24
THP	THP05040	Ø5 x 40	✓*	--	4,47	--	4,47	--	3,13	--	3,13
	THP05060	Ø5 x 60	✓*	6,79	4,47	<u>5,46</u>	4,47	4,75	3,13	4,75	3,13
	THP06040	Ø6 x 40	✓								
	THP06050	Ø6 x 50	✓								
	THP06060	Ø6 x 60	✓	9,25	2,78	<u>8,35</u>	<u>8,35</u>	6,47	2,54	7,44	6,24
	THP06080	Ø6 x 80	✓								
	THP06100	Ø6 x 100	✓								
	THP08060	Ø8 x 60	✓								
THP08080	Ø8 x 80	✓	11,77	6,28	<u>13,05</u>	<u>13,05</u>	8,24	4,39	10,46	9,49	

*Ø5 Homologado solamente para uso en hormigón y en losas alveolares prefabricadas para sistemas no-estructurales redundantes

6.3 CARGAS MAXIMAS RECOMENDADAS (APLICACIONES ESTRUCTURALES) [kN] (con $\gamma_F= 1.4$) [kN]

Parámetros generales				Hormigón no fisurado				Hormigón fisurado			
Familia	Código	Medida	Homologado ETA	Tracción $N_{rec, ucr}$		Cortadura $V_{rec, ucr}$		Tracción $N_{rec, cr}$		Cortadura $V_{rec, cr}$	
				($h_{ef, std}$)	($h_{ef, red}$)	($h_{ef, std}$)	($h_{ef, red}$)	($h_{ef, std}$)	($h_{ef, red}$)	($h_{ef, std}$)	($h_{ef, red}$)
THE	THE05040	Ø5 x 40	✓*	--	3,20	--	3,20	--	2,24	--	2,24
	THE05050	Ø5 x 50	✓*	4,85	3,20	<u>3,90</u>	3,20	3,40	2,24	3,40	2,24
	THE05060	Ø5 x 60	✓*								
	THE05080	Ø5 x 80	✓*								
	THE05100	Ø5 x 100	✓*								
	THE06035	Ø6 x 35	✓	--	1,98	--	<u>5,97</u>	--	1,81	--	4,46
	THE06040	Ø6 x 40	✓	--		--					
	THE06045	Ø6 x 45	✓	--		--					
	THE06050	Ø6 x 50	✓	--		--					
	THE06060	Ø6 x 60	✓	6,61	1,98	<u>5,97</u>	<u>5,97</u>	4,62	1,81	5,32	4,46
	THE06070	Ø6 x 70	✓								
	THE06080	Ø6 x 80	✓								
	THE06100	Ø6 x 100	✓								
	THE06120	Ø6 x 120	✓	8,41	4,48	<u>9,32</u>	<u>9,32</u>	5,88	3,14	7,47	6,78
	THE08055	Ø8 x 55	✓								
	THE08060	Ø8 x 60	✓								
	THE08070	Ø8 x 70	✓								
	THE08075	Ø8 x 75	✓								
	THE08080	Ø8 x 80	✓								
	THE08090	Ø8 x 90	✓								
	THE08100	Ø8 x 100	✓								
	THE08110	Ø8 x 110	✓								
	THE08120	Ø8 x 120	✓	12,85	6,26	<u>13,05</u>	12,21	8,99	4,38	<u>13,05</u>	8,55
	THE08140	Ø8 x 140	✓								
	THE10060	Ø10 x 60	✓								
	THE10070	Ø10 x 70	✓								
	THE10080	Ø10 x 80	✓	--	10,35	--	<u>17,73</u>	--	7,24	--	16,88
	THE10090	Ø10 x 90	✓								
	THE10100	Ø10 x 100	✓								
	THE10120	Ø10 x 120	✓								
	THE10140	Ø10 x 140	✓	17,87	10,35	<u>17,73</u>	<u>17,73</u>	12,51	7,24	<u>17,73</u>	16,88
	THE10160	Ø10 x 160	✓								
THE10180	Ø10 x 180	✓									
THE12080	Ø12 x 80	✓									
THE12090	Ø12 x 90	✓	--	20,67	10,35	<u>25,10</u>	25,10	14,47	7,24	<u>25,10</u>	18,47
THE12100	Ø12 x 100	✓									
THE12110	Ø12 x 110	✓									
THE12130	Ø12 x 130	✓									
THE12150	Ø12 x 150	✓	20,67	10,35	<u>27,60</u>	22,14	14,47	7,24	<u>27,60</u>	15,50	
THE14080	Ø14 x 80	✓									
THE14100	Ø14 x 100	✓									
THE14110	Ø14 x 110	✓									
THE14120	Ø14 x 120	✓	27,77	13,57	<u>38,47</u>	36,10	19,44	9,50	<u>38,47</u>	25,27	
THE14130	Ø14 x 130	✓									
THE14140	Ø14 x 140	✓									
THE14160	Ø14 x 160	✓									
TFE16100	Ø16 x 100	✓	--	--	--	--	14,47	7,24	<u>27,60</u>	15,50	
TFE16150	Ø16 x 150	✓									
THE18100	Ø18 x 100	✓	--	13,57	--	36,10	--	9,50	--	25,27	
THE18130	Ø18 x 130	✓									
THE18160	Ø18 x 160	✓									
THE18180	Ø18 x 180	✓									
THE18200	Ø18 x 200	✓	27,77	13,57	<u>38,47</u>	36,10	19,44	9,50	<u>38,47</u>	25,27	

*Ø5 Homologado solamente para uso en hormigón y en losas alveolares prefabricadas para sistemas no-estructurales redundantes

Parámetros generales				Hormigón no fisurado				Hormigón fisurado			
Familia	Código	Medida	Homologado ETA	Tracción $N_{Rk, ucr}$		Cortadura $V_{Rk, ucr}$		Tracción $N_{Rk, cr}$		Cortadura $V_{Rk, cr}$	
				($h_{ef, std}$)	($h_{ef, red}$)	($h_{ef, std}$)	($h_{ef, red}$)	($h_{ef, std}$)	($h_{ef, red}$)	($h_{ef, std}$)	($h_{ef, red}$)
THA	THA05040	Ø5 x 40	✓*	--	3,20	--	3,20	--	2,24	--	2,24
	THA05060	Ø5 x 60	✓*	4,85	3,20	<u>3,90</u>	3,20	3,40	2,24	3,40	2,24
	THA05080	Ø5 x 80	✓*								
	THA05100	Ø5 x 100	✓*								
	THA06045	Ø6 x 45	✓	--	1,98	--	<u>5,97</u>	--	1,81	--	4,46
	THA06050	Ø6 x 50	✓	6,61	1,98	<u>5,97</u>	<u>5,97</u>	4,62	1,81	5,32	4,46
	THA06060	Ø6 x 60	✓								
	THA06080	Ø6 x 80	✓								
	THA06100	Ø6 x 100	✓								
	THA06120	Ø6 x 120	✓								
	THA06140	Ø6 x 140	✓	8,41	4,48	<u>9,32</u>	<u>9,32</u>	5,88	3,14	7,47	6,78
	THA08060	Ø8 x 60	✓								
	THA08080	Ø8 x 80	✓								
	THA08100	Ø8 x 100	✓								
THA08120	Ø8 x 120	✓									
THA10100	Ø10 x 100	✓	12,85								
THA10120	Ø10 x 120	✓									
THT06040	Ø6 x 40	✓		--	1,98	--	<u>5,97</u>	--	1,81	--	4,46
THT	THT06050	Ø6 x 50	✓	6,61	1,98	<u>5,97</u>	<u>5,97</u>	4,62	1,81	5,32	4,46
	THT06060	Ø6 x 60	✓								
	THP05040	Ø5 x 40	✓*								
THP	THP05060	Ø5 x 60	✓*	4,85	3,20	<u>3,90</u>	3,20	3,40	2,24	3,40	2,24
	THP06040	Ø6 x 40	✓								
	THP06050	Ø6 x 50	✓	--	1,98	--	<u>5,97</u>	--	1,81	--	4,46
	THP06060	Ø6 x 60	✓	6,61	1,98	<u>5,97</u>	<u>5,97</u>	4,62	1,81	5,32	4,46
	THP06080	Ø6 x 80	✓								
	THP06100	Ø6 x 100	✓								
	THP08060	Ø8 x 60	✓	--	4,48	--	<u>9,32</u>	--	3,14	--	6,78
	THP08080	Ø8 x 80	✓	8,41	4,48	<u>9,32</u>	<u>9,32</u>	5,88	3,14	7,47	6,78

*Ø5 Homologado solamente para uso en hormigón y en losas alveolares prefabricadas para sistemas no-estructurales redundantes

COEFICIENTES DE MAYORACIÓN A EXTRACCIÓN PARA CARGA A TRACCIÓN EN HORMIGONES DE ALTA RESISTENCIA ψ_c															
Diámetro	Ø5		Ø6		Ø8		Ø10			Ø12		Ø14		Ø18	
Profundidad de instalación	($h_{ef, red}$)	($h_{ef, std}$)	($h_{ef, red}$)	($h_{ef, std}$)	($h_{ef, red}$)	($h_{ef, std}$)	($h_{ef, 1}$)	($h_{ef, 2}$)	($h_{ef, 3}$)	($h_{ef, red}$)	($h_{ef, std}$)	($h_{ef, red}$)	($h_{ef, std}$)	($h_{ef, red}$)	($h_{ef, std}$)
C30/37	1,00	1,00	1,16	1,22	1,21	1,22	1,22	1,17	1,22	1,16	1,22	1,21	1,20	1,22	1,17
C40/50	1,00	1,00	1,28	1,41	1,39	1,41	1,41	1,30	1,41	1,29	1,41	1,39	1,37	1,40	1,32
C50/60	1,00	1,00	1,39	1,58	1,54	1,58	1,58	1,42	1,58	1,40	1,58	1,55	1,51	1,57	1,42

7. RESISTENCIAS (LOSAS ALVEOLARES)

Resistencias en losas alveolares C30/37 para un anclaje aislado sin efectos de distancia al borde ni de distancias entre anclajes es la indicada en la siguiente tabla:

Los valores subrayados y en cursiva indican fallo del acero, los valores en **negrita** indican fallo por hormigón y el resto indica fallo por extracción.

1 KN ≈ 100 kg

7.1 RESISTENCIAS CARACTERÍSTICAS (APLICACIONES NO ESTRUCTURALES) [kN]

Parámetros generales				Losas Alveolares					
Familia	Código	Medida	Homologado ETA	Tracción N _{Rk}			Cortadura V _{Rk}		
				(h _{ef1})	(h _{ef2})	(h _{ef3})	(h _{ef1})	(h _{ef2})	(h _{ef3})
THE	THE05040	Ø5 x 40	✓*	5,39	--	--	5,39	--	--
	THE05050	Ø5 x 50	✓*		--	--		--	--
	THE05060	Ø5 x 60	✓*		6,22	8,22		6,22	<u>8,19</u>
	THE05080	Ø5 x 80	✓*						
	THE05100	Ø5 x 100	✓*						
	THE06035	Ø6 x 35	✓	5,39	--	--	5,39	--	--
	THE06040	Ø6 x 40	✓		--	--		--	--
	THE06045	Ø6 x 45	✓		--	--		--	--
	THE06050	Ø6 x 50	✓		6,22	7,99		6,22	7,99
	THE06060	Ø6 x 60	✓						
	THE06070	Ø6 x 70	✓						
	THE06080	Ø6 x 80	✓						
	THE06100	Ø6 x 100	✓						
THE06120	Ø6 x 120	✓							
THA	THA05040	Ø5 x 40	✓*	5,39	--	--	5,39	--	--
	THA05060	Ø5 x 60	✓*		6,22	8,22		6,22	<u>8,19</u>
	THA05080	Ø5 x 80	✓*						
	THA05100	Ø5 x 100	✓*						
	THA06045	Ø6 x 45	✓	5,39	--	--	5,39	--	--
	THA06050	Ø6 x 50	✓		--	--		--	--
	THA06060	Ø6 x 60	✓		6,22	7,99		6,22	7,99
	THA06080	Ø6 x 80	✓						
	THA06100	Ø6 x 100	✓						
THA06120	Ø6 x 120	✓							
THA06140	Ø6 x 140	✓							
THT	THT06040	Ø6 x 40	✓	5,39	--	--	5,39	--	--
	THT06050	Ø6 x 50	✓		6,22	7,99		6,22	7,99
	THT06060	Ø6 x 60	✓						
THP	THP05040	Ø5 x 40	✓*	5,39	--	--	5,39	--	--
	THP05060	Ø5 x 60	✓*		6,22	8,22		6,22	<u>8,19</u>
	THP06040	Ø6 x 40	✓	5,39	--	--	5,39	--	--
	THP06050	Ø6 x 50	✓		6,22	7,99		6,22	7,99
	THP06060	Ø6 x 60	✓						
	THP06080	Ø6 x 80	✓						
THP06100	Ø6 x 100	✓							

*Ø5 Homologado solamente para uso en hormigón y en losas alveolares prefabricadas para sistemas no-estructurales redundantes

7.2 RESISTENCIAS DE CALCULO (APLICACIONES NO ESTRUCTURALES) [kN]									
Parámetros generales				Losas Alveolares					
Familia	Código	Medida	Homologado ETA	Tracción N _{Rd}			Cortadura V _{Rd}		
				(h _{ef1})	(h _{ef2})	(h _{ef3})	(h _{ef1})	(h _{ef2})	(h _{ef3})
THE	THE05040	Ø5 x 40	✓*	2,99	--	--	3,59	--	--
	THE05050	Ø5 x 50	✓*		--	--		--	--
	THE05060	Ø5 x 60	✓*		3,45	4,57		4,14	5,46
	THE05080	Ø5 x 80	✓*						
	THE05100	Ø5 x 100	✓*						
	THE06035	Ø6 x 35	✓	2,99	--	--	3,59	--	--
	THE06040	Ø6 x 40	✓		--	--		--	--
	THE06045	Ø6 x 45	✓						
	THE06050	Ø6 x 50	✓						
	THE06060	Ø6 x 60	✓		3,45	4,44		4,14	5,33
	THE06070	Ø6 x 70	✓						
	THE06080	Ø6 x 80	✓						
THE06100	Ø6 x 100	✓							
THE06120	Ø6 x 120	✓							
THA	THA05040	Ø5 x 40	✓*	2,99	--	--	3,59	--	--
	THA05060	Ø5 x 60	✓*		3,45	4,57		4,14	5,46
	THA05080	Ø5 x 80	✓*						
	THA05100	Ø5 x 100	✓*						
	THA06045	Ø6 x 45	✓	2,99		--	3,59	--	--
	THA06050	Ø6 x 50	✓			--			--
	THA06060	Ø6 x 60	✓						
	THA06080	Ø6 x 80	✓		3,45	4,44		4,14	5,33
	THA06100	Ø6 x 100	✓						
THA06120	Ø6 x 120	✓							
THA06140	Ø6 x 140	✓							
THT	THT06040	Ø6 x 40	✓	2,99	--	--	3,59	--	--
	THT06050	Ø6 x 50	✓		3,45	4,44		4,14	5,33
	THT06060	Ø6 x 60	✓						
THP	THP05040	Ø5 x 40	✓*	2,99	--	--	3,59	--	--
	THP05060	Ø5 x 60	✓*		3,45	4,57		4,14	5,46
	THP06040	Ø6 x 40	✓	2,99	--	--	3,59	--	--
	THP06050	Ø6 x 50	✓						
	THP06060	Ø6 x 60	✓		3,45	4,44		4,14	5,33
	THP06080	Ø6 x 80	✓						
THP06100	Ø6 x 100	✓							

*Ø5 Homologado solamente para uso en hormigón y en losas alveolares prefabricadas para sistemas no-estructurales redundantes

7.3 CARGAS MAXIMAS RECOMENDADAS (APLICACIONES NO ESTRUCTURALES) [kN] (con $\gamma F= 1.4$) [kN]									
Parámetros generales				Losas Alveolares					
Familia	Código	Medida	Homologado ETA	Tracción N_{rec}			Cortadura V_{rec}		
				(h_{ef1})	(h_{ef2})	(h_{ef3})	(h_{ef1})	(h_{ef2})	(h_{ef3})
THE	THE05040	Ø5 x 40	✓*	2,14	--	--	2,57	--	--
	THE05050	Ø5 x 50	✓*		--	--		--	--
	THE05060	Ø5 x 60	✓*		2,47	3,26		2,96	3,90
	THE05080	Ø5 x 80	✓*						
	THE05100	Ø5 x 100	✓*						
	THE06035	Ø6 x 35	✓	2,14	--	--	2,57	--	--
	THE06040	Ø6 x 40	✓		--	--		--	--
	THE06045	Ø6 x 45	✓						
	THE06050	Ø6 x 50	✓						
	THE06060	Ø6 x 60	✓		2,47	3,17		2,96	3,80
	THE06070	Ø6 x 70	✓						
	THE06080	Ø6 x 80	✓						
THE06100	Ø6 x 100	✓							
THE06120	Ø6 x 120	✓							
THA	THA05040	Ø5 x 40	✓*	2,14	--	--	2,57	--	--
	THA05060	Ø5 x 60	✓*		--	--		--	--
	THA05080	Ø5 x 80	✓*		2,47	3,26		2,96	3,90
	THA05100	Ø5 x 100	✓*						
	THA06045	Ø6 x 45	✓	2,14	--	--	2,57	--	--
	THA06050	Ø6 x 50	✓						
	THA06060	Ø6 x 60	✓						
	THA06080	Ø6 x 80	✓		2,47	3,17		2,96	3,80
	THA06100	Ø6 x 100	✓						
THA06120	Ø6 x 120	✓							
THA06140	Ø6 x 140	✓							
THT	THT06040	Ø6 x 40	✓	2,14	--	--	2,57	--	--
	THT06050	Ø6 x 50	✓		2,47	3,17		2,96	3,80
	THT06060	Ø6 x 60	✓						
THP	THP05040	Ø5 x 40	✓*	2,14	--	--	2,57	--	--
	THP05060	Ø5 x 60	✓*		2,47	3,26		2,96	3,90
	THP06040	Ø6 x 40	✓	2,14	--	--	2,57	--	--
	THP06050	Ø6 x 50	✓						
	THP06060	Ø6 x 60	✓		2,47	3,17		2,96	3,80
	THP06080	Ø6 x 80	✓						
THP06100	Ø6 x 100	✓							

*Ø5 Homologado solamente para uso en hormigón y en losas alveolares prefabricadas para sistemas no-estructurales redundantes

8. DOCUMENTACION OFICIAL

A través de nuestro departamento comercial o de nuestra página web www.indexfix.com puede obtener los siguientes documentos:

- Homologación europea ETA 20/0046 para instalación en hormigón fisurado y no fisurado según guía EAD 330232-01-0601, opción 1, de Ø6 a Ø18.
- Homologación europea ETA 20/0494 para uso en hormigón y en losas alveolares prefabricadas para sistemas no-estructurales redundantes según guía EAD 330747-00-0601 de Ø5 a Ø6.
- Declaración de prestaciones DoP THE.
- Certificado VdS CEA 4001:2021-01(07) *Guidelines for sprinklers systems. Planning and installation for applications of water extinguishing systems on concrete elements* de Ø8 a Ø18.
- Disponible para el programa de cálculo de anclajes INDEXcal.